

QuickChange Mill Angle Sets

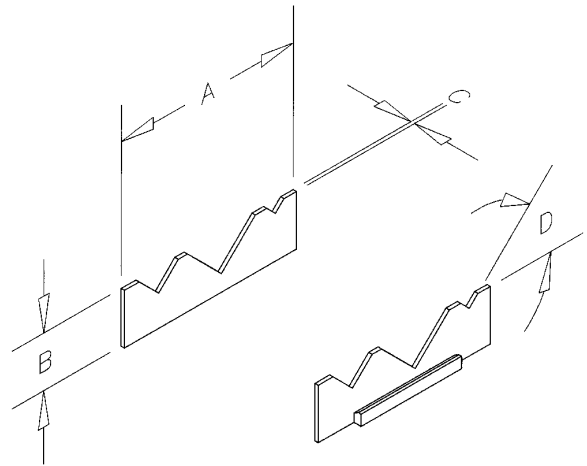

- QuickChange Mill Angles are designed to be used with QuickChange Master Jaws on page 185.
- Individual QuickChange Mill Angles are on page 186.
- QuickChange Starter Package available on page 188.

Vise Size	Part Number	A	B	C	(1 of each degree) D
4"	QMA4000	4.000	1.240	.118	20 25 30 35 40 45
6"	QMA6000	6.000	1.740	.118	20 25 30 35 40 45
8"	QMA8000	8.000	2.230	.118	20 25 30 35 40 45

QuickChange "V" Jaws

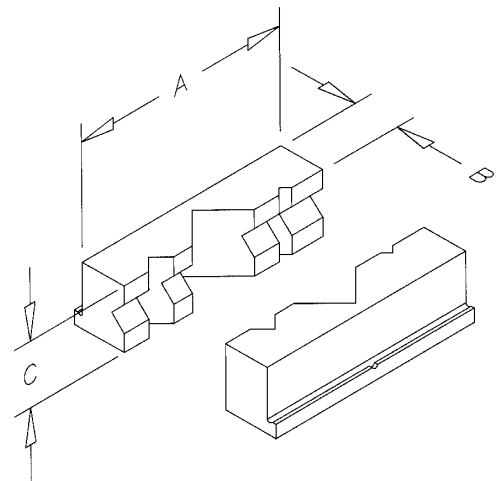
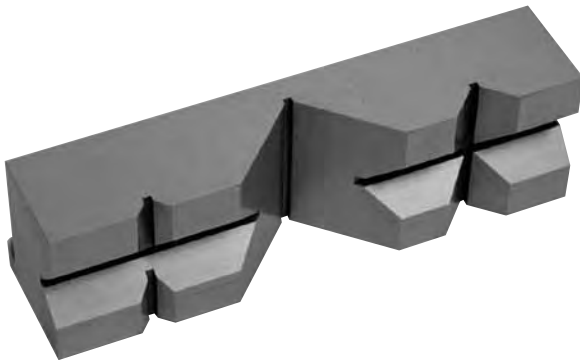

- Designed to be used with QuickChange Master Jaws on page 185.
- QuickChange Starter Package available on page 188.
- Sold as individual units.

Vise Size	Part Number	A	B	C
4"	QVJ4000	4.00	1.00	1.24
6"	QVJ6000	6.00	1.25	1.74
8"	QVJ8000	8.00	1.75	2.24