

Torque Wrench

- Come with the pre-set foot poundage, providing consistent torque and preventing operators from over-tightening the vise.
- The TWR4002 has been pre-set to 55 foot pounds. The TWR6002 has foot poundage pre-set at 100 foot pounds.
- Using the torque wrenches for Toolex 8-station vises requires an adapter that fits onto the hex drive.



Part Number	Description
TWR4002	*Torque wrench for RWS4002 and RWS4008
TWR6002	*Torque wrench for RWS6002 and RWS6008

*Adapter required for 8-station vises

Vise Mounting Kit: Part No. 90442

Designed for 6" single station vises



Kit contains:

- Two 1/2 x 3 Studs
- Two 1/2 x 5/8 T-Nuts
- Two 1/2 - 13 Flange Nuts
- Two 1/2 Flat Washers
- One T-Slot Cleaner

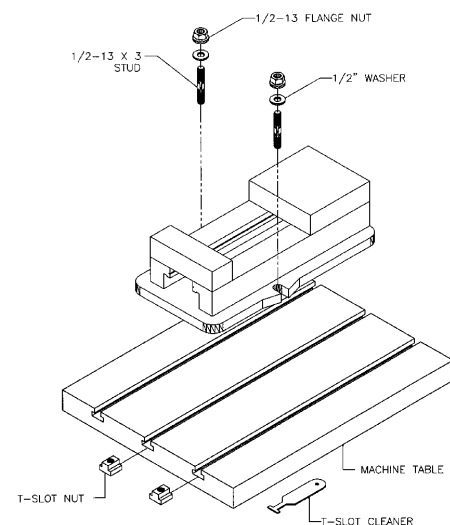

QuickStop

- Universal mounting bracket mounts to many vise configurations.
- After tightening, handles can be rotated 360 degrees for tool and cutter clearance.
- Fully adjustable to adapt to many workpiece configurations.



Vise Size	Part Number	Thread Size
4"	QVS4000	3/8-16
6"	QVS6000	1/2-13
8"	QVS8000	5/8-11