

## Lever Type Steel Plunger: Non-Locking

- Fully retractable plunger
- Chamfered plunger for easy alignment
- Easy withdrawing and re-engagement
- Zinc Plated Clear Chromate finish

Part No.	End Force (lbs)		Thread A	B	C	D	Hex E	F	G	H	I
	Initial	Final									
54310	.50	2.50	1/4-20	1.25	.38	.16	.25	.50	.09	.80	*
54311	.75	3.75	3/8-16	2.00	.56	.25	.38	.75	.14	1.31	.13
54312	1.0	5.0	1/2-13	2.00	.75	.31	.50	1.0	.19	1.25	.15
54313	1.0	5.0	5/8-11	3.05	1.0	.38	.62	1.0	.19	2.0	.18

\*No thread relief in 1/4-20 thread size

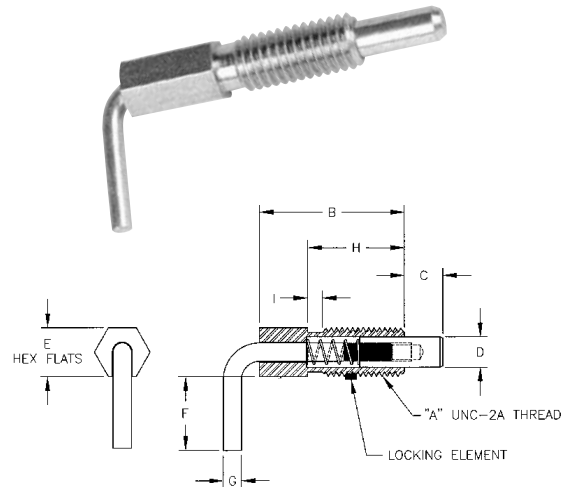

## Lever Type Steel Stubby Plunger: Locking

- Designed for applications where space is limited
- Fully retractable plunger
- Chamfered plunger for easy alignment
- Zinc Plated Clear Chromate finish

Part No.	End Force (lbs)		Thread A	B	C	D	Hex E	F	G	H	I
	Initial	Final									
54350	.12	.50	1/4-20	.75	.20	.16	.25	.40	.09	.50	*
54351	.25	1.25	3/8-16	1.13	.30	.25	.38	.56	.14	.75	.13
54352	.50	2.0	1/2-13	1.50	.40	.31	.50	.75	.19	1.0	.15
54353	.75	2.5	5/8-11	1.88	.50	.38	.62	.88	.19	1.25	.18

\*No thread relief in 1/4-20 thread size

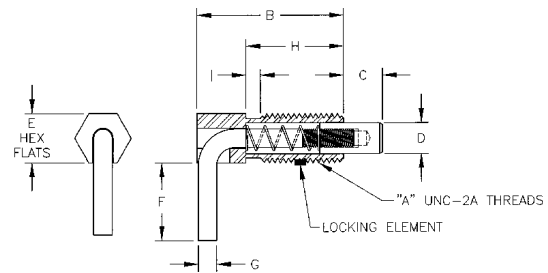

## Lever Type Steel Stubby Plunger: Non-Locking

- Designed for applications where space is limited
- Fully retractable plunger
- Chamfered plunger for easy alignment
- Zinc Plated Clear Chromate finish

Part No.	End Force (lbs)		Thread A	B	C	D	Hex E	F	G	H	I
	Initial	Final									
54360	.12	.50	1/4-20	.75	.20	.16	.25	.40	.09	.50	*
54361	.25	1.25	3/8-16	1.13	.30	.25	.38	.56	.14	.75	.13
54362	.50	2.0	1/2-13	1.50	.40	.31	.50	.75	.19	1.0	.15
54363	.75	2.5	5/8-11	1.88	.50	.38	.62	.88	.19	1.25	.18

\*No thread relief in 1/4-20 thread size

