

5/16-18 UNC - 2B ∇ .75
(4) EACH SIDE

$\varnothing .5005^{+.0005}_{-.0000}$ X .55 DP.
(4) PLACES

FROM OPP. SIDE
DRILLED AND C'BORED
FOR 5/16-18 SHCS

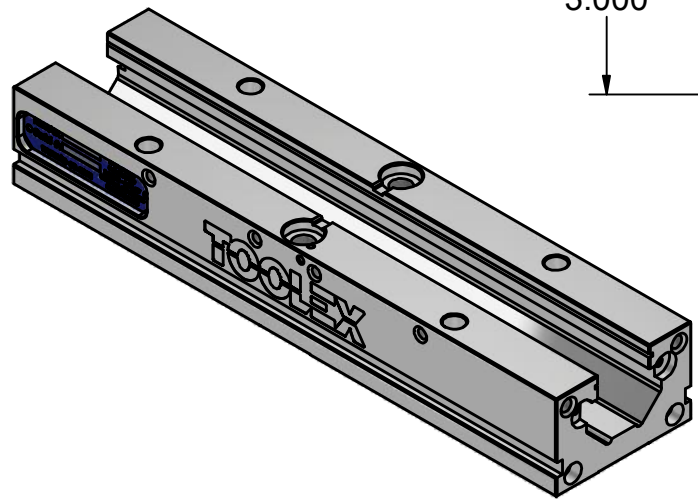
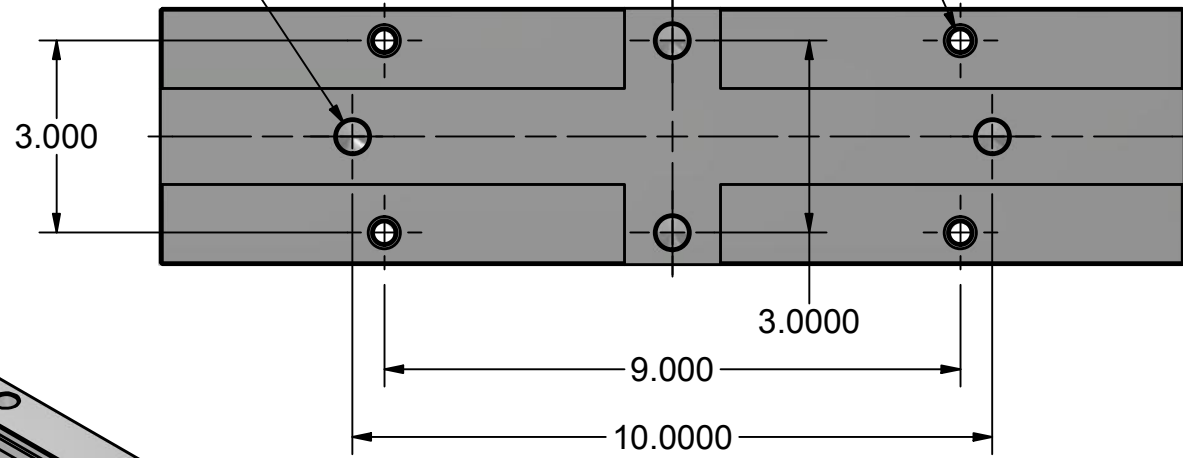

TECHNICAL INFO

FEMALE HEX SIZE = .500"
 TORQUE MAX = 56 FTLBS
 CLAMPING PRESSURE = 0 TO 6000 LBS
 BODY MATERIAL = 80000 PSI DUCTILE CAST IRON
 MECHANISM MATERIAL = DUCTILE IRON

		WEIGHT: 33 LBS.
PART NUMBER:		RWS4002
DESCRIPTION:		4" RELOK 2 STATION LAYDOWN VISE