

## Vertical Cam Operated Straight Index Plungers Finished and Unfinished Ground

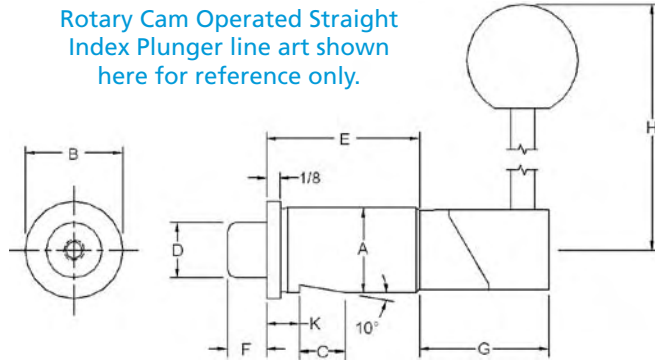

Rotary Cam Operated Straight Index Plunger line art shown here for reference only.



- For material information, contact TE-CO
- Many sizes conform to TCMAI standards
- Bushing not included – see page 53
- Vertical cam allows for quick vertical motion

Use line art image on pg. 56 (Rotary style) for dimensions A-F, J, and K.

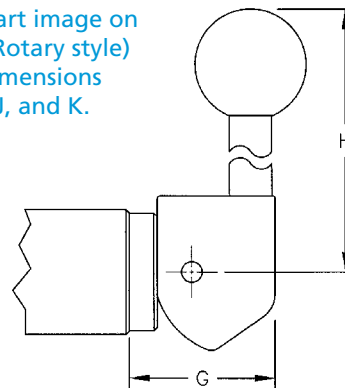

### Finished Ground

Part No.	A*	B	C	D	E	F	G	H	J	K	Use with Bushing No.	Wt. (lbs/100 pcs)
54950	.7518/.7515	7/8	7/16	1/2	1-3/8	23/64	1	3	1/8	5/16	54980	33
54952	1.1268/1.1265	1-1/4	9/16	3/4	2	33/64	1-5/16	3-1/2	1/8	3/8	54982	90
54954	1.5022/1.5018	1-5/8	11/16	1	2-1/4	5/8	1-7/16	4-1/2	1/8	7/16	54984	167
54956	2.023/2.0019	2-3/16	**	1-3/8	3	27/32	1-5/8	5-3/4	3/16	**	54986	354

### Unfinished Ground

Part No.	A*	B	C	D	E	F	G	H	J	K	Use with Bushing No.	Wt. (lbs/100 pcs)
54951	.770/.765	7/8	7/16	1/2	1-3/8	23/64	1	3	1/8	5/16	54981	33
54953	1.145/1.140	1-1/4	9/16	3/4	2	33/64	1-5/16	3-1/2	1/8	3/8	54983	90
54955	1.520/1.515	1-5/8	11/16	1	2-1/4	5/8	1-7/16	4-1/2	1/8	7/16	54985	167
54957	2.020/2.015	2-3/16	**	1-3/8	3	27/32	1-5/8	5-3/4	3/16	**	54987	354

\*For proper installation use nominal drill diameter

\*\*Whistle notch not included for this part number