

FROM OPP. SIDE:
DRILLED AND C'BORED
FOR 5/16-18 SHCS

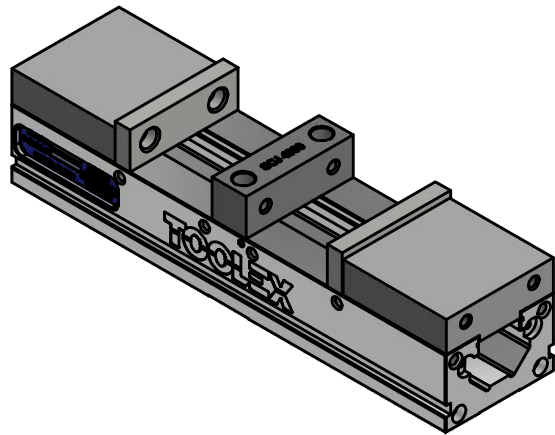
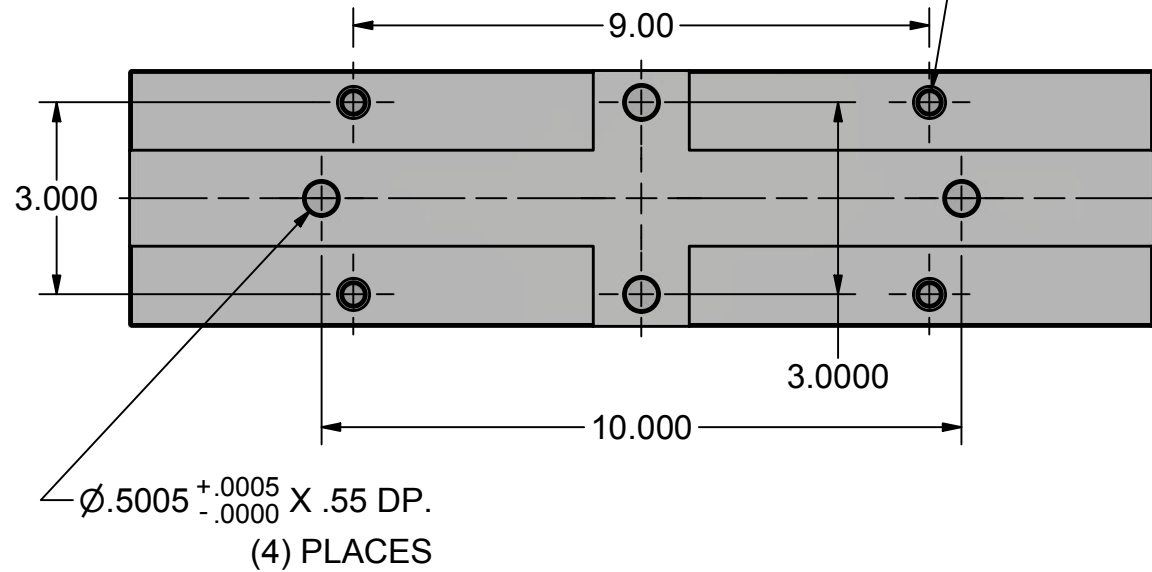

TECHNICAL INFO

FEMALE HEX SIZE = .500"
 TORQUE MAX = 56 FTLBS
 CLAMPING PRESSURE = 0 TO 6000 LBS
 BODY MATERIAL = 80000 PSI DUCTILE CAST IRON
 MECHANISM MATERIAL = DUCTILE IRON
 JAW MATERIAL = (CARRIERS = 6061 ALUMINUM) (HARD JAWS = STEEL)

	WEIGHT:
	PART NUMBER: RWS4002HJ
DESCRIPTION: 4" RELOK 2 STA. LAYDN W/ HARD JAWS	